



SERVICE LETTER 00085

Date Released: March 19, 2025
Date Effective: March 19, 2025
Subject: Flap Actuator Retrofit
Affected Models: RV-8/8A
Required Action: None – Optional change
Supersedes Notice: NONE
Level of Certification: N/A

Synopsis:

Due to the discontinuation of the ES 85615-157-1 Flap Actuator, the upgraded ES-FA-PA-270-12-5 Flap Actuator with integral potentiometer will now be offered in its place.

Materials Required:

The following materials are required to complete the steps necessary to achieve compliance with this Service Letter:

Purchase SL-00085 KIT-8

Method of Compliance:

Step 1: Remove the F-876-L-1.

Step 2: Disconnect and discard the ES 85615-157-1.

Step 3: Remove and set aside the A-406-1 for later use.

Step 4: Use the provided TOOL-00111 as a template to enlarge the slot as shown in Figure 1.

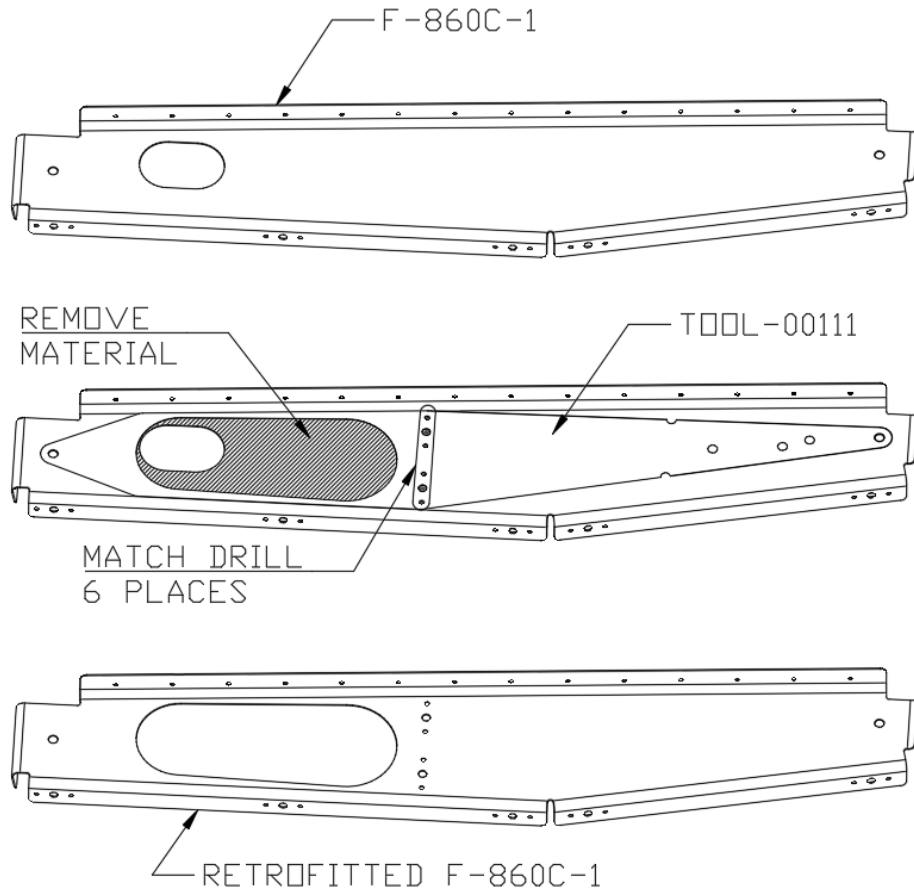

FIGURE 1: RETROFITTING F-860C-1

Step 5: Cut TOOL-00111 to make what will now be referred to as the TOOL-00111 ALTERED TOOL-00111 shown in Figure 2.

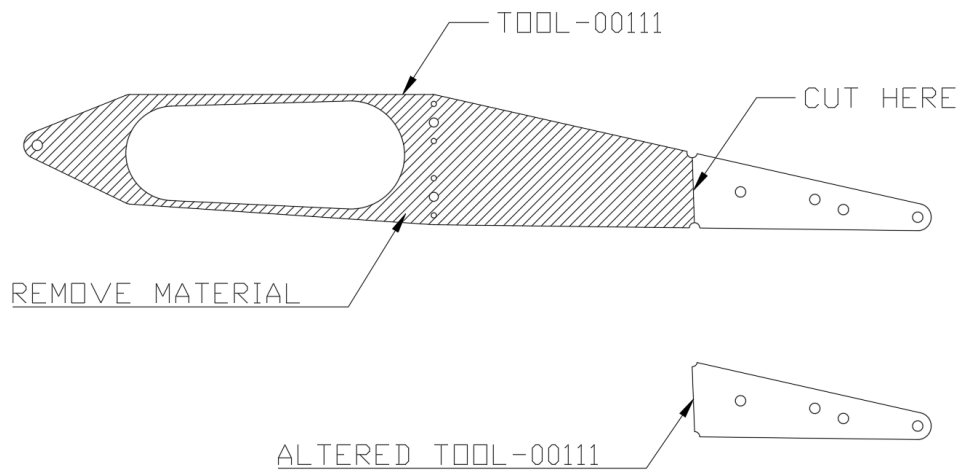

FIGURE 2: ALTERATIONS TO TOOL-00111

Step 6: Temporarily bolt the ALTERED TOOL-00111 to the F-807A-L-1 and match-drill two 3/16 holes from the tool into the F-807A-L-1 as shown in Figure 3.

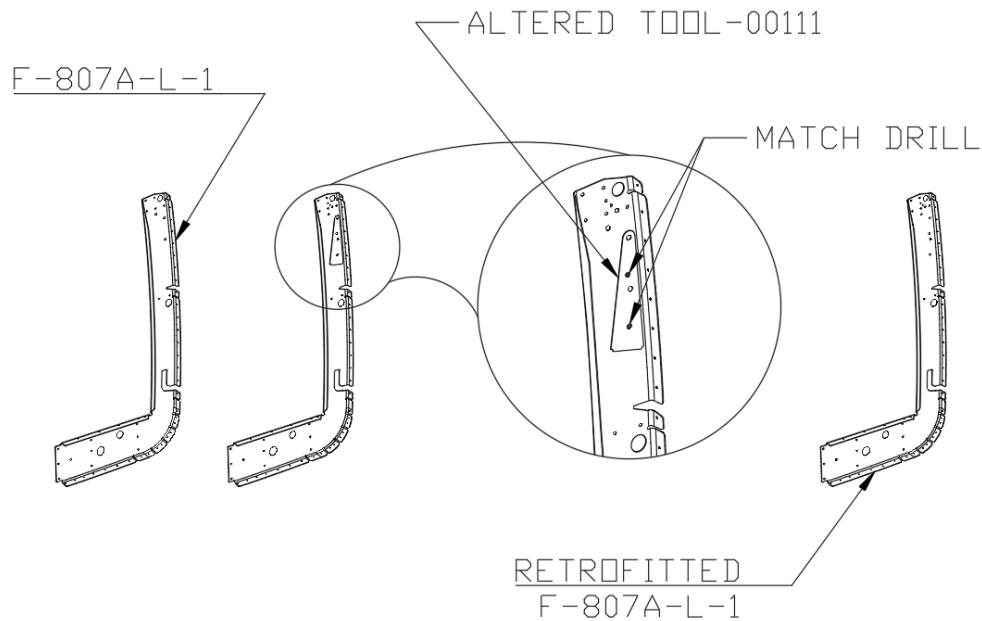

FIGURE 3: RETROFITTING F-807A-L-1

NOTE: From this point forward follow the steps in revised Electric Flap Installation DWG 69, 79 and Manual Section 8. Some of the steps are only applicable for new builds and can be skipped.

Make a logbook entry indicating compliance with service document per the requirements of the controlling authority/agency.

If you are no longer in possession of this aircraft, please forward this information to the present owner/operator and immediately notify Van's Aircraft, Inc. via email at registrations@vansaircraft.com. Please include the new owner's contact information and date the aircraft ownership transferred.

Information regarding establishing/transferring aircraft ownership, registration and licensing is available at: <https://www.vansaircraft.com/gr/transfer-of-ownership/>