

Step 1: Machine countersink all rivet hole locations on the F-1202A Instrument Panel. Install the instrument panel with the hardware called out in Figure 1.

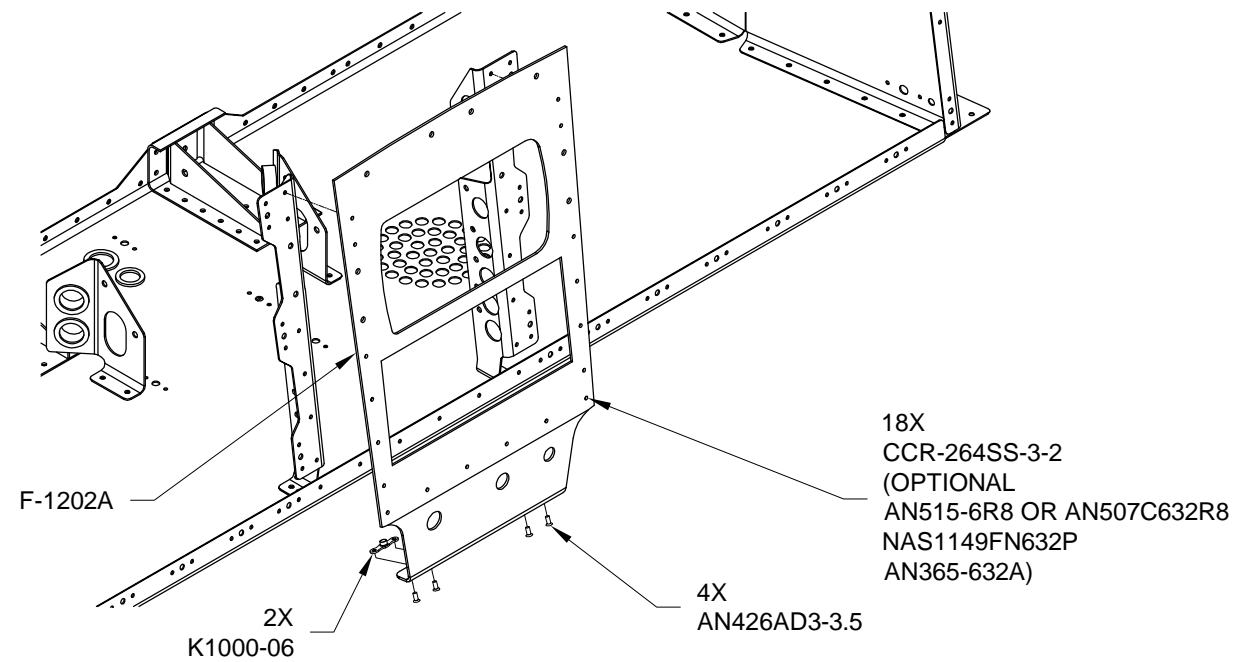

**FIGURE 1: INSTALLING THE INSTRUMENT PANEL**

**NOTE: If installing the Optional Dual Efis Kit, do not install the F-1202U Instrument Panel Right Mapbox.**

Step 2: Re-Install the F-1240 Assembly using the hardware called out on 29-05 Figure 4. Install the F-1202T Instrument Panel Left D-180, F-1202U Instrument Panel Right Mapbox and Map Box Assembly with the screws called out in Figure 2.

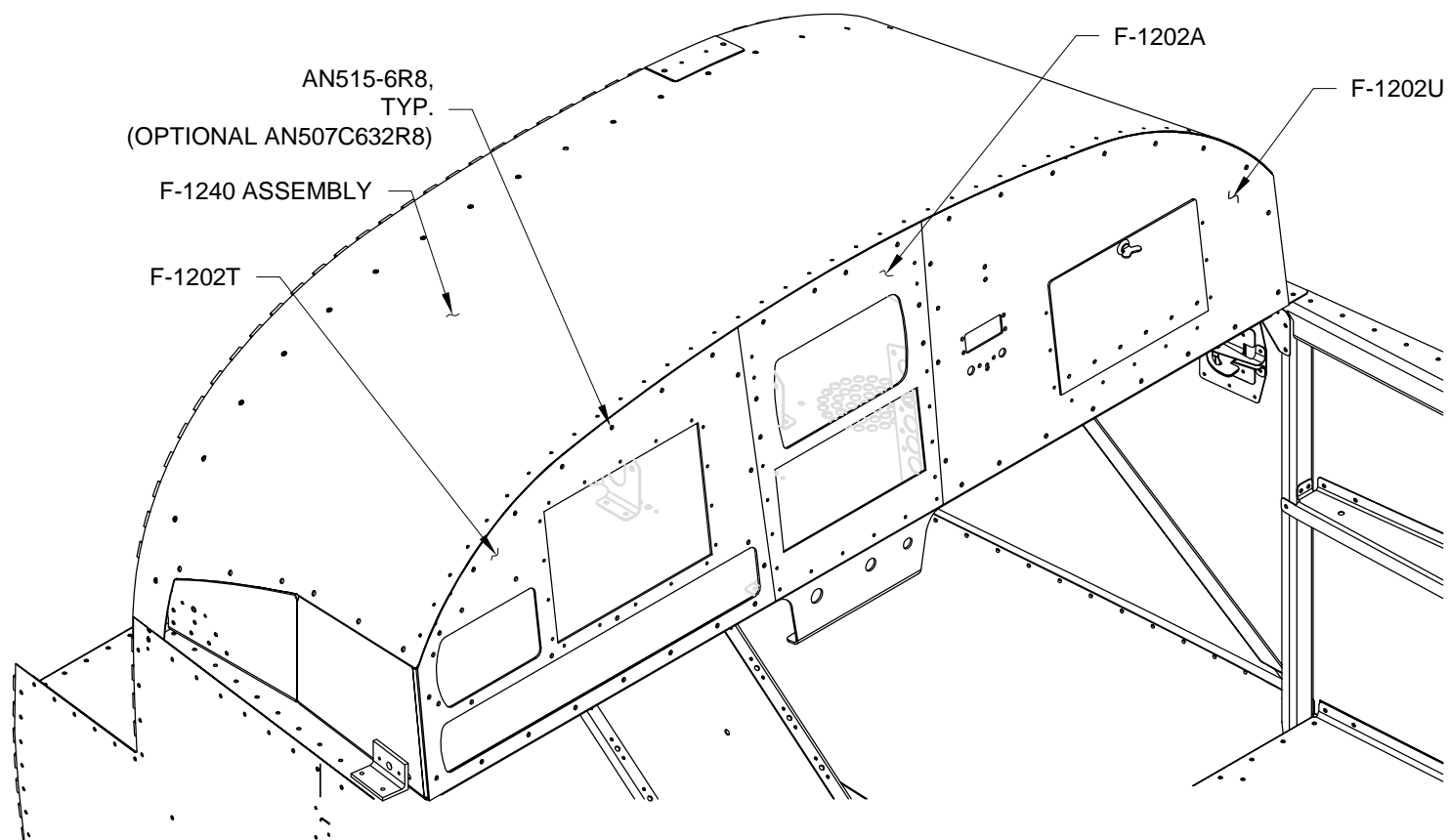

**FIGURE 2: INSTALLING THE INSTRUMENT PANEL LEFT AND RIGHT**

Step 3: Install the screws, washers and nuts to anchor the back of the map box as shown in Figure 3.

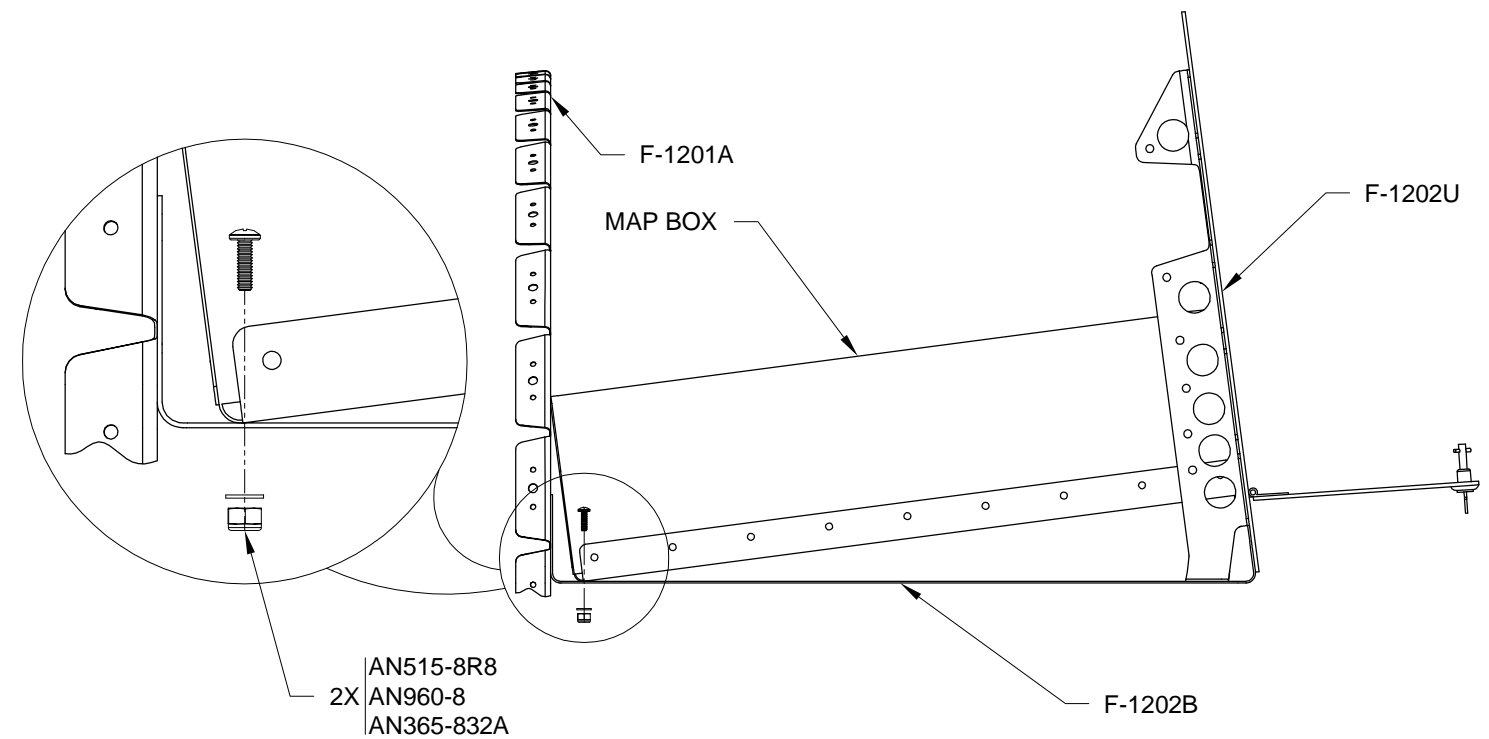

**FIGURE 3: INSTALLING MAPBOX SCREWS (SOME PARTS NOT SHOWN FOR CLARITY)**