

Step 1: Dimple all the #30 holes and #40 nutplate attach holes in the area indicated in Figure 1 in both the F-1213-L & -R Step Floors. DO NOT dimple the nutplate screw holes.

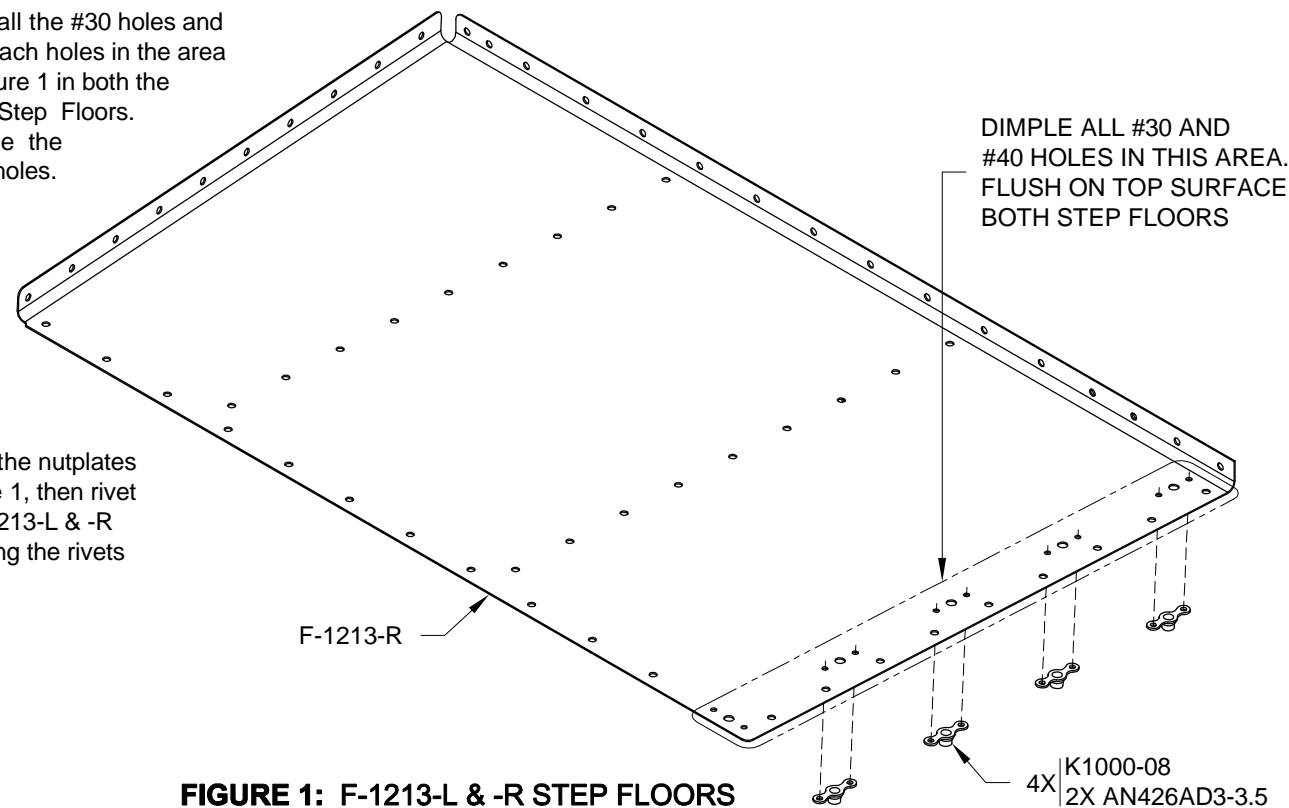

FIGURE 1: F-1213-L & -R STEP FLOORS

Step 2: Dimple the nutplates shown in Figure 1, then rivet them to the F-1213-L & -R Seat Floors using the rivets called out.

Step 3: Rivet the F-1213-L & -R Step Floors to the F-1202F Bulkhead, the F-1212-L & -R Step Ribs, and the F-1203A Bulkhead using the rivets called out in Figure 2. Be sure to capture the two holes in the front flange of the F-1253-L & -R Seat Floor Supports when riveting the two outboard holes of the step floors to the bulkhead.

Step 4: Dimple the nutplates shown in Figure 2, then reach through the lightening holes in the F-1212-L & -R Step Ribs and rivet the nutplates to the top flange of the F-1202F Bulkhead and to the F-1213-L & -R Step Floors using the rivets called out.

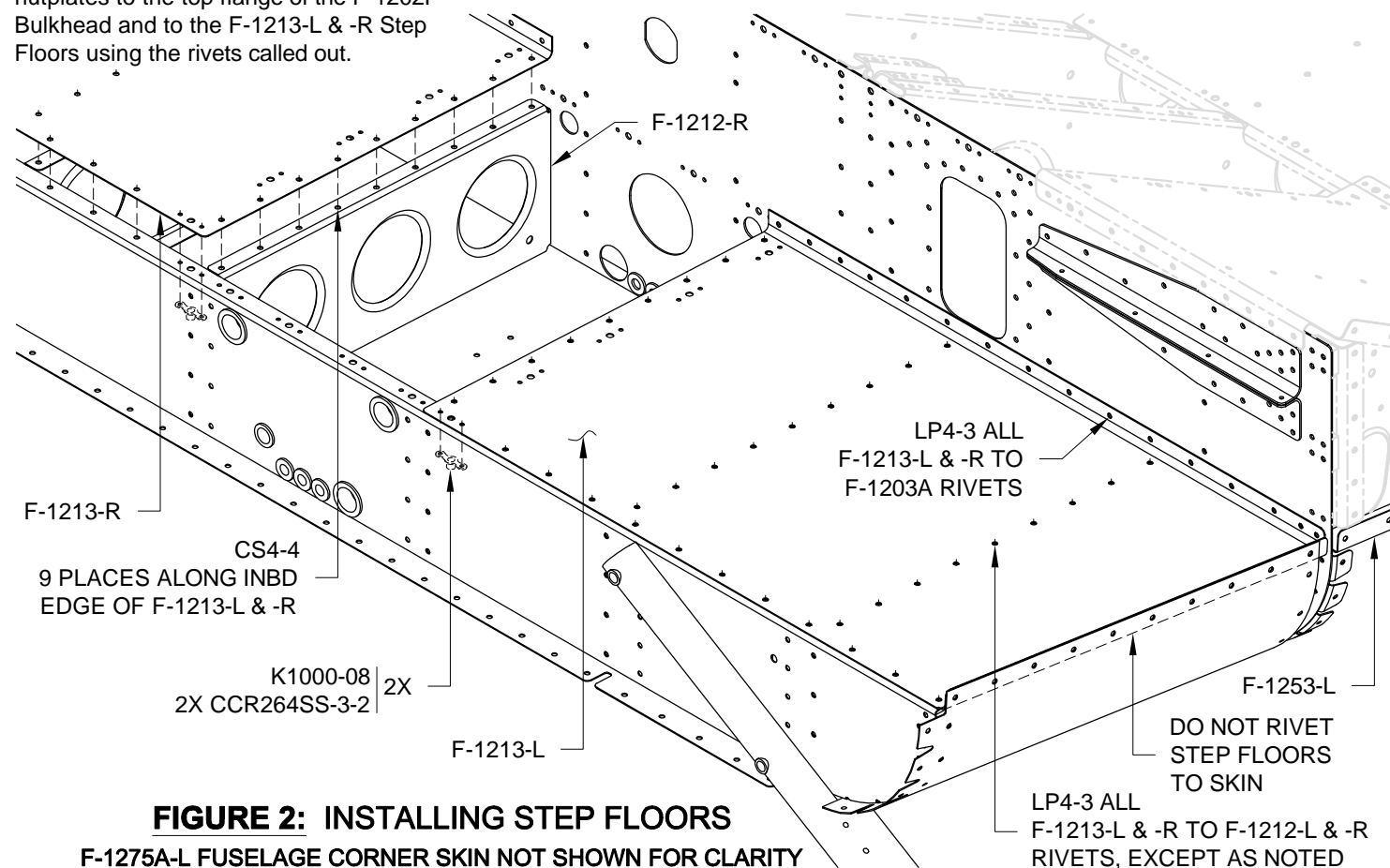

FIGURE 2: INSTALLING STEP FLOORS
F-1275A-L FUSELAGE CORNER SKIN NOT SHOWN FOR CLARITY

Step 5: Dimple the four sets of nutplate attach rivet holes in the F-1207B Baggage Bulkhead for the nutplates shown in Figure 3.

Step 6: Dimple the nutplates, then rivet them to the F-1207B Baggage Bulkhead using the rivets called out in Figure 3.

NOTE: For autopilot bracket installation refer to Section 39.

Step 7: Cleco the F-1207B Baggage Bulkhead in place, then rivet the baggage bulkhead to the F-1206G-L & -R Baggage Ribs using the rivets called out in Figure 3. Rivet to these two ribs only, leave the rest of the baggage bulkhead clecoed.

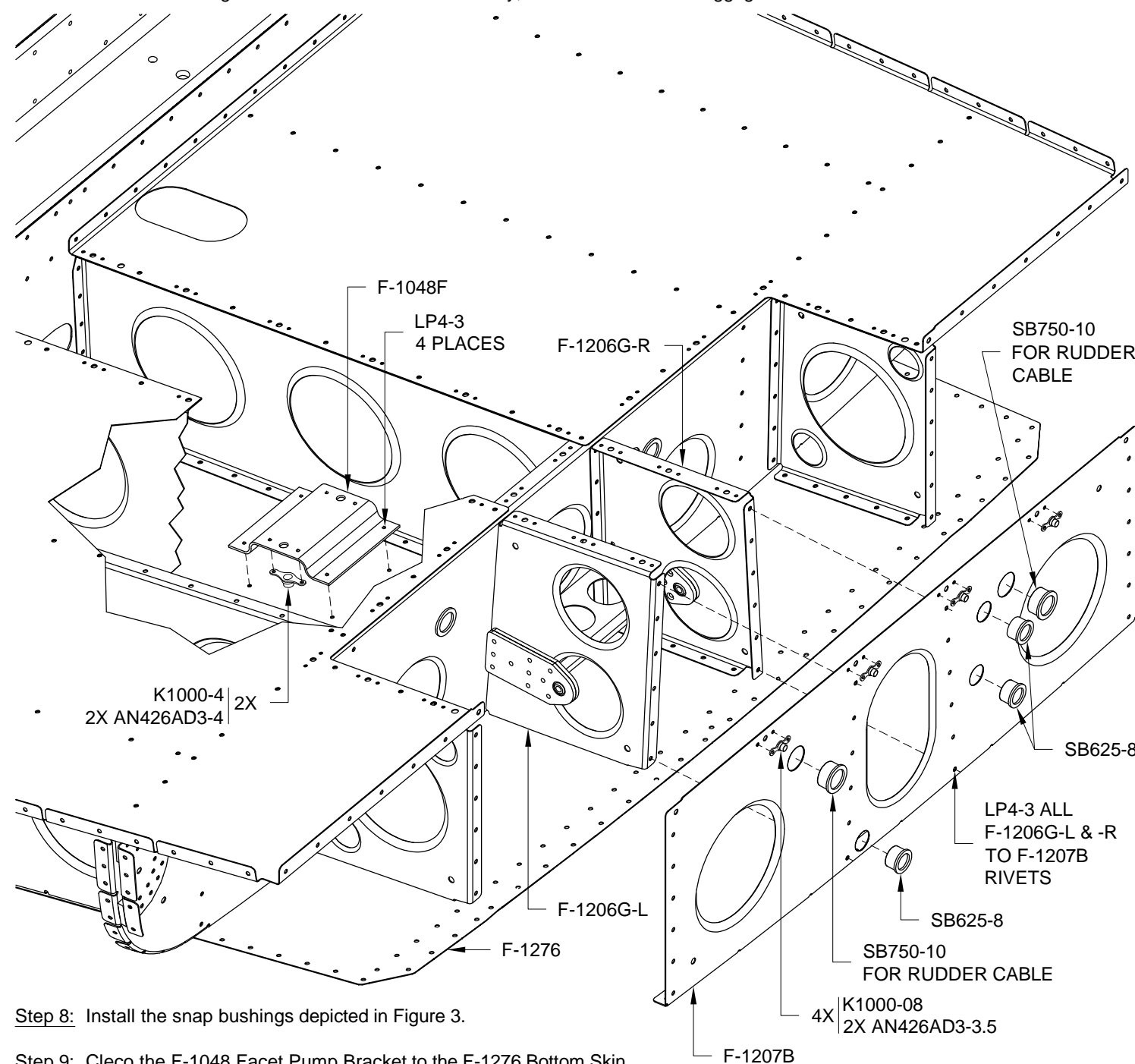

Step 8: Install the snap bushings depicted in Figure 3.

Step 9: Cleco the F-1048 Facet Pump Bracket to the F-1276 Bottom Skin as shown in Figure 3, then final-drill #30 the four holes common to both parts.

Step 10: Remove the F-1048 Facet Pump Bracket, final-drill #40 and machine countersink the nutplate attach rivet holes, then attach the nutplates shown in Figure 3 with the rivets called out.

Step 11: Rivet the F-1048 Facet Pump Bracket to the F-1276 Bottom Skin using the rivets called out in Figure 3.

FIGURE 3: ATTACHING THE F-1207B BULKHEAD