

NOTE: Refer to Figure 1 for Steps 1 through 4 on this page.

Install all fittings with the clocking angle depicted in Figure 1.

Step 1: Install a KB-000 Straight fitting into the fuel pump inlet on the right side of the engine driven fuel pump. Install a KB-090-T Tee Fitting to the fuel pump outlet on the left side of the engine driven fuel pump. Install a VA-128 Restrictor Fitting into the female port in the tee fitting. Install an F 69-F-04X02 Brass Elbow to the overflow port on the aft side of the engine driven fuel pump (leave the nut and ferrule on at this time).

Step 2: Install an AN823-8D 45° Elbow fitting in both oil cooler ports.

Step 3: Install a VA-128 Restrictor Fitting into the oil pressure port.

Step 4: Install a AN816-4D Nipple in the manifold pressure/ priming port on the #5 Cylinder.

Step 5: Install the PROP GOV MT P-420-17 to the front of the engine per the instructions supplied with the governor. See Figure 2.

NOTE: Install any other accessories to rear of the engine at this time.

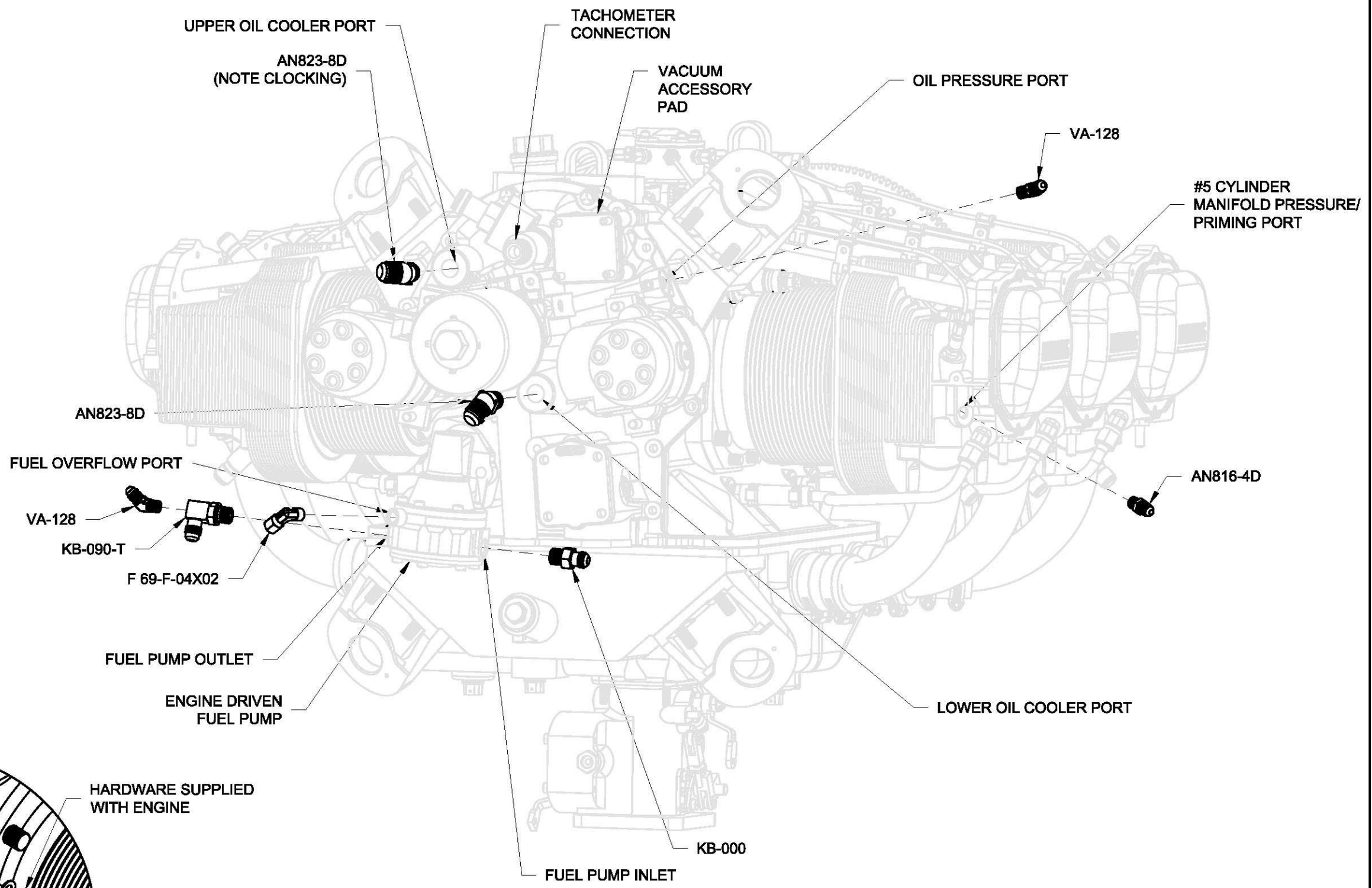

FIGURE 1: ATTACHING FLUID AND PRESSURE FITTINGS TO THE ENGINE

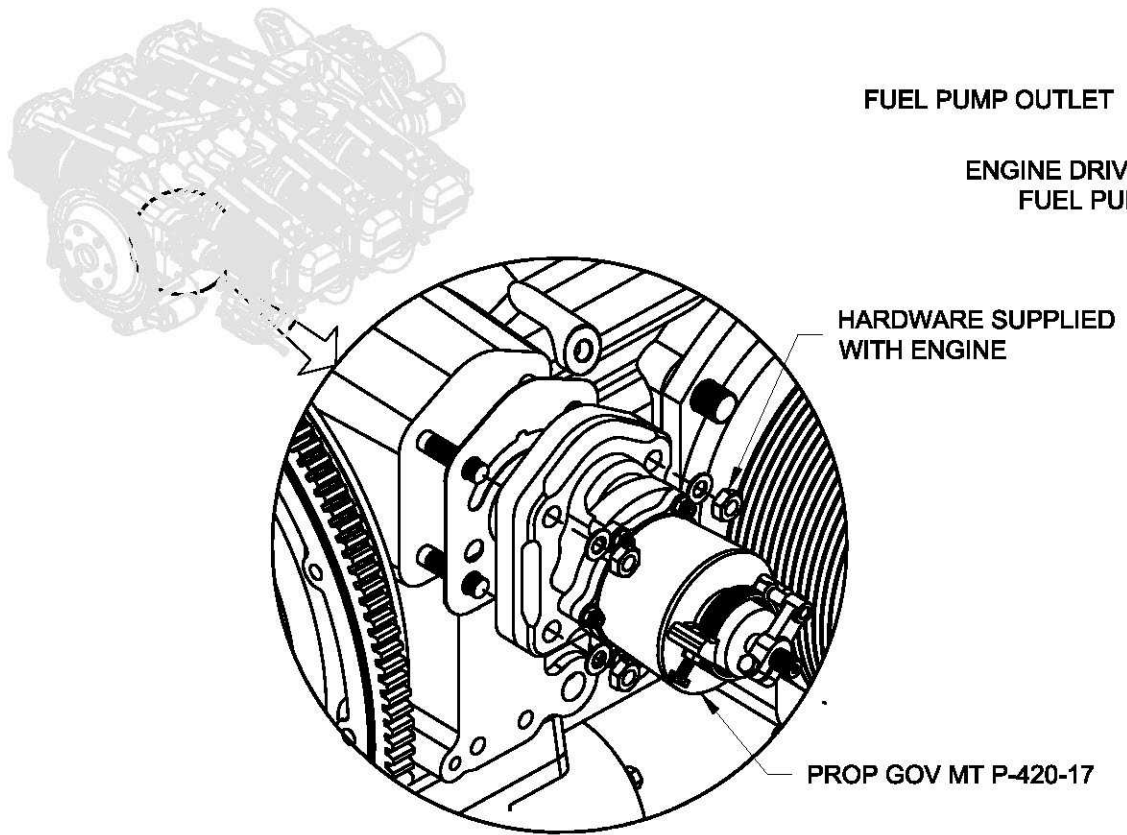

FIGURE 2: INSTALLING THE PROPELLER GOVERNOR