

# RV-7/7A QUICKBUILD ORDER FORM

10-20-09

Customer Number (assigned w/ emp kit)		
Name		
Mailing address		
Shipping address (if different)		
Day phone		
e-mail		
Fax		
Eve phone		

**PLEASE READ AND SIGN BELOW**

1. Kit prices are prices in effect the day order is received.
2. A 25% deposit must accompany kit orders.
3. Customer-instigated delays may result in price increases.
4. Kits must be paid in full before they can be shipped.
5. \$500.00 non-refundable if order is cancelled.
6. Payment in U.S. funds: check, money order, or Visa/Mastercard.
7. Kit/plans orders must be in writing (mail or FAX).
8. Prices are FOB Aurora, Oregon.
9. Freight charges payable on delivery.
10. Van's Aircraft, Inc. cannot assist in certifying kits outside the USA.
11. Prices are subject to change without notice.

**Signature:** \_\_\_\_\_

If you have completed, registered, and flown an RV, put customer number of completed aircraft here: \_\_\_\_\_

<b>PREVIEW PLANS SET</b> (required purchase before beginning construction)		\$55.00	
<b>RVATOR SUBSCRIPTION</b> Receive 6 issues of Van's company newsletter. On-line version available at no charge.	In USA,	\$15.00	
	outside USA,	\$20.00	
<b>EMPENNAGE KIT</b>		<b>\$1600.00</b>	
Empennage Options (enter total from reverse side of form)			

<b>QUICKBUILD KIT (includes wings and fuselage)</b> if ordering QuickBuild Wing-only Kit or QuickBuild Fuselage-only Kit, use Standard Order Form. (circle and enter one) <span style="float: right;">RV-7 <b>\$21,980.00</b> (or) RV-7A <b>\$22,670.00</b></span>	
<b>SELECT ONE:</b> <span style="margin-left: 100px;"><b>SLIDING CANOPY</b></span> (or) <span style="margin-left: 100px;"><b>TIP-UP CANOPY</b></span>	
Wing/Fuselage Options(enter total from reverse side of form)	

<b>FINISHING KIT</b> If you are NOT taking advantage of Van's special OEM pricing on new Lycoming engines and are obtaining an engine from another source, you must use the Special Finishing Kit order form. Use this form to order a Finishing Kit ONLY if you are purchasing a new engine from Van's. NOTE THAT VAN'S HAS NO SUITABLE COWLING OR FIREWALL FWD KIT FOR THE FUEL INJECTED IO-320-D1A ENGINE. (circle and enter one) <span style="float: right;">RV-7 <b>\$6080.00</b> (or) RV-7A <b>\$6250.00</b></span>				
Spinner type required (circle one)	Hartzell constant-speed	Sensenich fixed-pitch	Wood fixed-pitch	None (\$120.00 credit)
Engine type (circle one)	O-320-D1A	O-360-A1A	IO-360-M1B	IO-360-A1B6
<b>Sliding Canopy</b>				\$100.00

<b>TOTAL CRATING CHARGES</b> (enter total from reverse side of form)		
<b>TOTAL ORDER</b>		
<b>METHOD OF PAYMENT</b> (if credit card, enter number/exp. date)		
<b>AMOUNT ENCLOSED</b> (25% minimum deposit required)		
<b>Authorization to use Credit Card for Final Payment</b> Yes No (circle one)		

**VAN'S AIRCRAFT, INC.**  
 14401 Keil Road NE, Aurora, Oregon USA 97002  
 (503) 678-6545 FAX (503) 678-6560  
[www.vansaircraft.com](http://www.vansaircraft.com) [info@vansaircraft.com](mailto:info@vansaircraft.com)

# OPTIONS

Choices and optional kits that are best installed during construction. Enter the amount for the option you are ordering in the box on the right.

Add the total for each airframe kit and enter that amount on the front of the form.

Circle the crating charges that apply, total, and enter the amount on the front of the form.

<b>WINGTIPS AND RUDDER BOTTOMS ARE DESIGNED FOR LIGHTS. IF YOU ARE <u>NOT</u> INSTALLING LIGHTS CHECK THIS BOX:</b>		
<b>EMPENNAGE OPTIONS</b>		
<b><u>ELECTRIC ELEVATOR TRIM:</u></b> Standard manual elevator trim is controlled with a vernier cable supplied with the Fuselage kit. Electric option uses the same trim tab but a servo motor installed in the elevator replaces the manual push-pull cable. Kit includes servo motor, formed metal parts, hardware and instructions. Weight comparable to standard manual installation. The Electric trim switch can be mounted in any convenient spot.	\$305.00	
<b>TOTAL: ENTER ON FRONT OF FORM.</b>		

<b>QUICKBUILD WING/FUSELAGE OPTIONS</b>		
<b><u>FLOAT FUEL SENDING UNITS</u></b> Arm with float senses fuel level. Works with Van's gauges and many other resistance gauges. Fits standard cover plates in wing kit. Includes gaskets. Two supplied -- one for each wing.	\$54.00	
<b><u>EXTERNAL STEP KIT:</u></b> Eases the big step up to the wing. May be installed on either or both sides.  <b>Circle one and enter price at right:</b> left, right, both	One step	\$95.00
	Both steps	\$190.00
<b><u>DUAL BRAKE KIT:</u></b> Includes master cylinders, brake pedals and hardware necessary to install brakes for the second seat.	\$185.00	
<b><u>STATIC AIR KIT:</u></b> Includes static ports and lines to the instrument panel.	\$19.00	
<b><u>ELECTRIC ELEVATOR TRIM CREDIT:</u></b> If you ordered electric elevator trim with your empennage, you won't need the manual trim cable. Subtract the cost from the kit price.	Credit, subtract \$80.00	
<b><u>MANUAL AILERON TRIM:</u></b> Simple, light and effective spring bias system trims the roll axis. Inexpensive, too.	\$46.00	
<b><u>ELECTRIC AILERON TRIM:</u></b> Includes servo motor, panel mount rocker switch and all hardware. May also be wired to "china hat" switch sold separately.	\$310.00	
<b>TOTAL: ENTER ON FRONT OF FORM.</b>		

<b>CRATING CHARGES</b> (these are NOT shipping charges)			
	Empennage	Quickbuild Wing/Fuselage	Finishing
<b>STANDARD</b>	\$18.00	\$500.00	\$65.00
<b>SEA FREIGHT</b>	\$25.00	\$525.00	\$85.00
<b>TOTAL CRATING CHARGES: ENTER ON FRONT OF FORM.</b>			

Name: \_\_\_\_\_ Date: \_\_\_\_\_ Customer number: \_\_\_\_\_

## VAN'S AIRCRAFT, INC.

14401 Keil Road NE, Aurora, Oregon USA 97002

(503) 678-6545 FAX (503) 678-6560

[www.vansaircraft.com](http://www.vansaircraft.com)    [info@vansaircraft.com](mailto:info@vansaircraft.com)

# RV-7/7A SPECIAL FINISHING KIT ORDER FORM

Use when installing engines not supplied by Van's

1-1-09

Customer Number (assigned w/ emp kit)		
Name		
Mailing address		
Shipping address (if different)		
Day phone		
e-mail:		
Fax		
Eve phone		

**PLEASE READ AND SIGN BELOW**

1. Kit prices are prices in effect the day order is received.
2. A 25% deposit must accompany kit orders.
3. Customer-instigated delays may result in price increases.
4. Kits must be paid in full before they can be shipped.
5. \$500.00 non-refundable if order is cancelled.
6. Payment in U.S. funds: check, money order, or Visa/Mastercard.
7. Kit/plans orders must be in writing (mail or FAX).
8. Prices are FOB Aurora, Oregon.
9. Freight charges payable on delivery.
10. Van's Aircraft, Inc. cannot assist in certifying kits outside the USA.
11. Prices are subject to change without notice.

**Signature:** \_\_\_\_\_

If you have completed, registered, and flown an RV, put customer number of completed aircraft here: \_\_\_\_\_

<b><u>FINISHING KIT</u></b>		<b>RV-7 \$6080.00</b>	
		<b>RV-7A \$ 6250.00</b>	
Crating Charge (enter one)		Regular \$65.00, Sea Freight \$85.00	
<b><u>CANOPY</u></b>	Slider \$100.00	Tip-up N/C	
<b>DEFINING YOUR ENGINE</b>			
<p>If you are using a new Lycoming from Van's use the regular Finish Kit Order Form. If you are using an engine from some other source, use this form. Van's engine mounts and cowls fit the engines we sell. NOTE THAT VAN'S HAS NO SUITABLE COWLING OR FIREWALL FWD KIT FOR THE FUEL INJECTED IO-320-D1A ENGINE. Other engine suppliers produce a wide variety of engines that may or may not correspond to Lycoming models.</p> <p>To provide us the information we need, you must complete the ENGINE IDENTIFICATION form on the reverse by circling the items that describe your engine. Without this information we cannot accept your order.</p> <p>If you are installing an engine that is not compatible with Lycoming style mounts or cowl, you may delete these items for credit. The exact amount of the credit will be determined by Van's.</p> <p>It is the customer's responsibility to provide accurate information. Van's Aircraft, Inc. is not responsible for costs incurred replacing or returning incorrectly ordered parts.</p>			
<b><u>ENGINE MOUNT</u></b>	Use data sheet on opposite side	None	
<b><u>COWL TYPE</u></b>	Use data sheet on opposite side	None	
<b><u>SPINNER TYPE</u></b> NOTE: if supplying own spinner or buying new MT prop (supplied with spinner) -circle none.	Hartzell constant-speed	Sensenich fixed-pitch	Wood fixed-pitch
			None (\$120.00 credit)

<b><u>TOTAL ORDER</u></b>		
<b><u>METHOD OF PAYMENT</u></b> (if credit card, enter number/exp. date)		
<b><u>AMOUNT ENCLOSED</u></b> (25% minimum deposit required)		
<b><u>Authorization to use Credit Card for Final Payment</u></b> Yes No (circle one)		

**VAN'S AIRCRAFT, INC.**  
 14401 NE Keil Road Aurora, Oregon USA 97002  
**(503) 678-6545 FAX (503) 678-6560**

ON THE WEB AT: [www.vansaircraft.com](http://www.vansaircraft.com) e-mail: [info@vansaircraft.com](mailto:info@vansaircraft.com)

# ENGINE IDENTIFICATION

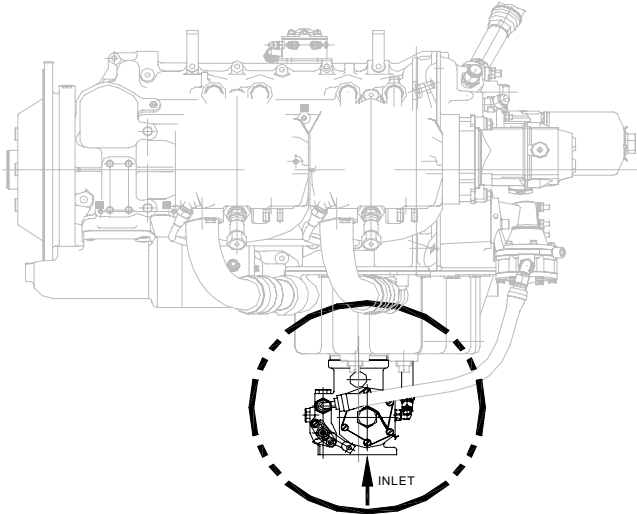

**VERTICAL INDUCTION**

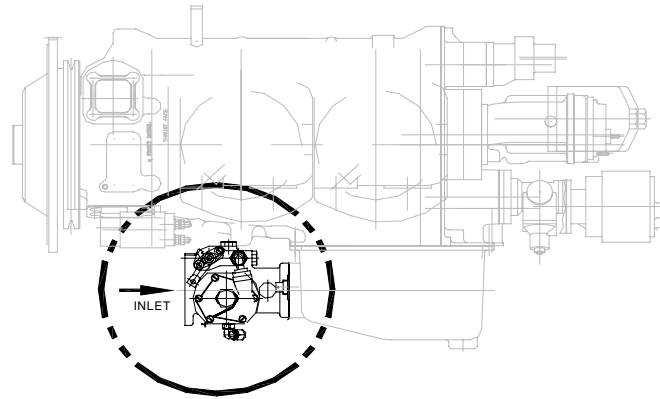

**HORIZONTAL INDUCTION**

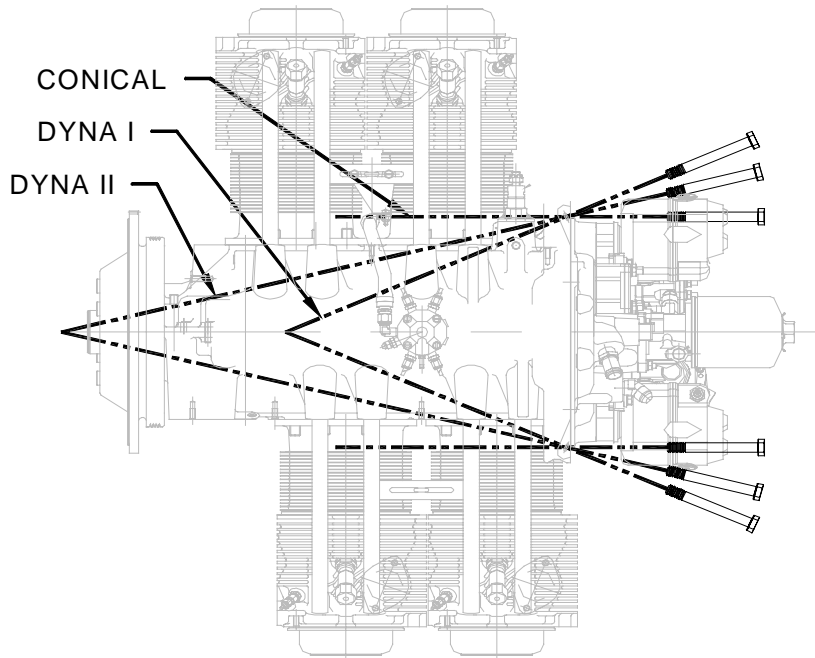

**ENGINE MOUNT STYLE**

## VALVE COVER SHAPE

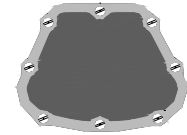

**ANGLE VALVE**  
EXAMPLE:  
IO-360 A1B6 (200 HP)

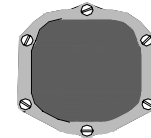

**PARALLEL VALVE**  
EXAMPLE:  
I(O)-320 D1A (150 - 160 HP)  
I(O)-360 A1A (180 HP)

## ENGINE STYLE

(PLEASE CIRCLE ONE FOR EACH CATEGORY)

**INDUCTION:**            VERTICAL OR HORIZONTAL

**CYLINDER TYPE:**    PARALLEL VALVE OR ANGLE VALVE

**DISPLACEMENT:**   235 OR 290 OR 320 OR 360 OR 540

**MOUNT STYLE:**       DYNAFOCAL I OR DYNAFOCAL II OR CONICAL

**FUEL METERING:**    FUEL INJECTED OR CARBURETTED

**ENGINE SUPPLIER:**   AERO SPORT POWER OR SUPERIOR OR  
MATTITUCK OR LYCOMING

OTHER \_\_\_\_\_

**CUSTOMER NAME:** \_\_\_\_\_

**CUSTOMER NUMBER:** \_\_\_\_\_