

RV-8/8A QUICKBUILD ORDER FORM

1-1-09

Customer Number (assigned w/ emp kit)		
Name		
Mailing address		
Shipping address (if different)		
Day phone		
e-mail		
Fax		
Eve phone		

PLEASE READ AND SIGN BELOW

1. Kit prices are prices in effect the day order is received.
2. A 25% deposit must accompany kit orders.
3. Customer-instigated delays may result in price increases.
4. Kits must be paid in full before they can be shipped.
5. \$500.00 non-refundable if order is cancelled.
6. Payment in U.S. funds: check, money order, or Visa/Mastercard.
7. Kit/plans orders must be in writing (mail or FAX).
8. Prices are FOB Aurora, Oregon.
9. Freight charges payable on delivery.
10. Van's Aircraft, Inc. cannot assist in certifying kits outside the USA.
11. Prices are subject to change without notice.

Signature: _____

If you have completed, registered, and flown an RV, put customer number of completed aircraft: _____

PREVIEW PLANS SET (required purchase before beginning construction)		\$55.00	
RVATOR SUBSCRIPTION Receive 6 printed issues of Van's company newsletter. On-line version available at no cost.	In USA,	\$15.00	
	outside USA,	\$20.00	
EMPENNAGE KIT		\$1550.00	
Empennage Options (enter total from reverse side of form)			

QUICKBUILD KIT (includes wings and fuselage) if ordering QuickBuild Wing-only Kit or QuickBuild Fuselage-only Kit, use Standard Order Form.		
(circle and enter one)	RV-8 \$23,620.00 (or) RV-8A \$22,970.00	
Wing/Fuselage Options(enter total from reverse side of form)		

FINISHING KIT If you are NOT taking advantage of Van's special OEM pricing on new Lycoming engines, and are obtaining an engine from another source, you must use the Special Finishing Kit Order Form. Use Standard or QuickBuild Kit Form to order a Finishing Kit ONLY if you are purchasing a new engine from Van's.					
(circle and enter one)	RV-8 \$5340.00 (or) RV-8A \$6240.00				
Spinner type required (circle one)	Hartzell constant-speed	Sensenich fixed-pitch	Wood fixed-	None (\$120.00 credit)	
Engine type (circle one)	O-320-D1A/D2G	IO-320-D1A	O-360-A1A	IO-360-M1B	IO-360-A1B6

TOTAL CRATING CHARGES (enter total from reverse side of form)		
TOTAL ORDER		
METHOD OF PAYMENT (if credit card, enter number/exp. date)		
AMOUNT ENCLOSED (25% minimum deposit required)		
Authorization to use Credit Card for Final Payment Yes No (circle one)		

VAN'S AIRCRAFT, INC.

14401 NE Keil Road Aurora, Oregon USA 97002

(503) 678-6545 FAX (503) 678-6560

ON THE WEB AT: www.vansaircraft.com e-mail: info@vansaircraft.com

OPTIONS

Choices and optional kits that are best installed during construction. Enter the amount for the option you are ordering in the box on the right. Add the total for each airframe kit and enter that amount on the front of the form.

Circle the crating charges that apply, total, and enter the amount on the front of the form.

WINGTIPS AND RUDDER BOTTOMS ARE DESIGNED FOR LIGHTS. IF YOU ARE NOT INSTALLING LIGHTS CHECK THIS BOX:		
EMPENNAGE KIT		
ELECTRIC ELEVATOR TRIM: Uses the same trim tab as the standard manual trim. A servo motor installed in the elevator replaces the manual push-pull cable. Kit includes formed servo motor, metal parts, hardware and instructions. Weight comparable to manual installation. Standard manual elevator trim is controlled with a vernier knob mounted on the lower left instrument panel supplied with the Fuselage kit. The electric trim switch can be mounted in any convenient spot.	\$305.00	

QUICKBUILD (WING/FUSELAGE) KIT		
FLOAT FUEL SENDING UNITS Arm with float senses fuel level. Works with Van's gauges and many other resistance gauges. Fits standard cover plates in wing kit. Includes gaskets. Two supplied -- one for each wing.	\$54.00	
MANUAL AILERON TRIM: Aileron trim is not standard on the RVs, but it is very useful. The manual option provides a simple, light and effective way of trimming out minor lateral imbalances due to uneven fuel burn, etc. A small lever displaces the ailerons very slightly through springs connected to the control system. Unnoticeable through the stick.	\$60.00	
ELECTRIC AILERON TRIM: Similar to manual trim, with no external tab, but uses electric servo to drive bias springs.	\$310.00	
STATIC AIR KIT: Includes static ports and lines to the instrument panel.	\$19.00	
REAR SEAT RUDDER PEDALS: Small round pedal extensions to allow the back seater to control the rudder. No brake provision. Specify for RV-8 or RV-8A.	RV-8 \$115.00	
	RV-8A \$225.00	
TALL PILOT OPTION: Provides more legroom in front seat, but less in the rear seat. For really tall people; 6'6" or 6'7".	\$5.00	
RUDDER PEDALS Choose between cockpit-adjustable sliding rudder pedals (can be adjusted while the pilot is seated in the cockpit) or ground-adjustable rudder pedals (adjustment requires hand tools and cannot be done while seated in the cockpit. Ground adjustable pedals are somewhat lighter and easier to install. Circle your choice below.		
COCKPIT-ADJUSTABLE SLIDING RUDDER PEDALS	N/C	
GROUND-ADJUSTABLE REPOSITIONABLE RUDDER PEDALS	Credit, subtract \$200.00	
MANUAL ELEVATOR TRIM CABLE: Mandatory if you've chosen manual trim in the empennage kit.	\$95.00	

CRATING CHARGES (these are NOT shipping charges)			
	Empennage	Quickbuild Wing/Fuselage	Finishing
STANDARD	\$18.00	\$500.00	\$65.00
SEA FREIGHT	\$25.00	\$525.00	\$85.00
TOTAL CRATING CHARGES: ENTER ON FRONT OF FORM.			

Name: _____ Date: _____ Customer number: _____

VAN'S AIRCRAFT, INC.
 14401 NE Keil Road Aurora, Oregon USA 97002
 (503) 678-6545 FAX (503) 678-6560

ON THE WEB AT: www.vansaircraft.com e-mail: info@vansaircraft.com

RV-8/8A SPECIAL FINISHING KIT ORDER FORM

Use when installing engines not supplied by Van's

1-1-09

Customer Number (assigned w/ emp kit)		
Name		
Mailing address		
Shipping address (if different)		
Day phone		
e-mail		
Fax		
Eve phone		

PLEASE READ AND SIGN BELOW

12. Kit prices are prices in effect the day order is received.
13. A 25% deposit must accompany kit orders.
14. Customer-instigated delays may result in price increases.
15. Kits must be paid in full before they can be shipped.
16. \$500.00 non-refundable if order is cancelled.
17. Payment in U.S. funds: check, money order, or Visa/Mastercard.
18. Kit/plans orders must be in writing (mail or FAX).
19. Prices are FOB Aurora, Oregon.
20. Freight charges payable on delivery.
21. Van's Aircraft, Inc. cannot assist in certifying kits outside the USA.
22. Prices are subject to change without notice.

Signature: _____

If you have completed, registered, and flown an RV, put customer number of completed aircraft here: _____

<u>FINISHING KIT</u>		RV-8 \$5340.00	
		RV-8A \$6240.00	
Crating Charge (enter one)		Regular \$65.00, Sea Freight \$85.00	
DEFINING YOUR ENGINE			
<p>If you are using a new Lycoming from Van's use the regular Finish Kit Order Form. If you are using an engine from some other source, use this form. Van's engine mounts and cowls fit the engines we sell. Other engine suppliers produce a wide variety of engines that may or may not correspond to Lycoming models.</p> <p>To provide us the information we need, you must complete the ENGINE IDENTIFICATION form on the reverse by circling the items that describe your engine. Without this information we cannot accept your order.</p> <p>If you are installing an engine that is not compatible with Lycoming style mounts or cowl, you may delete these items for credit. The exact amount of the credit will be determined by Van's.</p> <p>It is the customer's responsibility to provide accurate information. Van's Aircraft, Inc. is not responsible for costs incurred replacing or returning incorrectly ordered parts.</p>			
<u>ENGINE MOUNT</u>	Use data sheet on opposite side	None	
<u>COWL TYPE</u>	Use data sheet on opposite side	None	
<u>SPINNER TYPE</u> NOTE: if supplying own spinner or buying new MT prop (supplied with spinner) -circle none.	Hartzell constant-speed	Sensenich fixed-pitch	Wood fixed-pitch None \$120.00 credit
<u>TOTAL ORDER</u>			
<u>METHOD OF PAYMENT</u> (if credit card, enter number/exp. date)			
<u>AMOUNT ENCLOSED</u> (25% minimum deposit required)			
<u>Authorization to use Credit Card for Final Payment</u> Yes No (circle one)			

VAN'S AIRCRAFT, INC.

14401 NE Keil Road Aurora, Oregon USA 97002

(503) 678-6545 FAX (503) 678-6560

ON THE WEB AT: www.vansaircraft.com e-mail: info@vansaircraft.com

ENGINE IDENTIFICATION

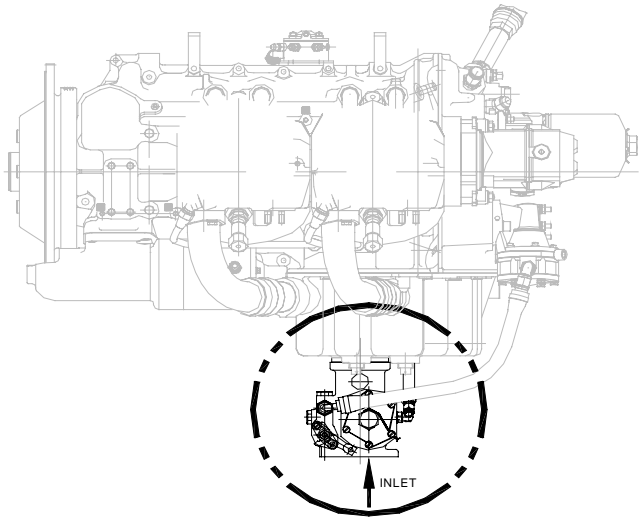

VERTICAL INDUCTION

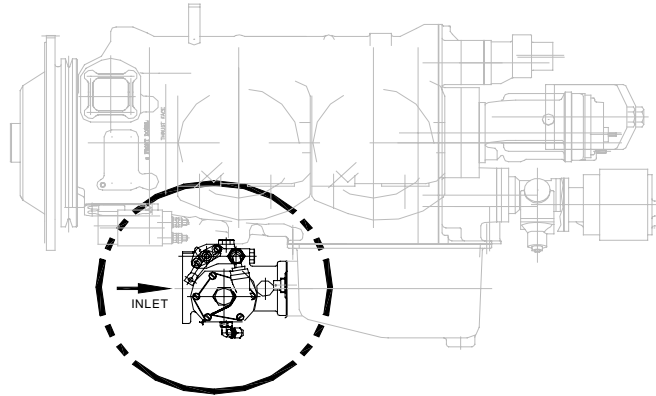

HORIZONTAL INDUCTION

VALVE COVER SHAPE



ANGLE VALVE

EXAMPLE:
IO-360 A1B6 (200 HP)

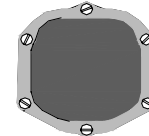

PARALLEL VALVE

EXAMPLE:
I(O)-320 D1A (150 - 160 HP)
I(O)-360 A1A (180 HP)

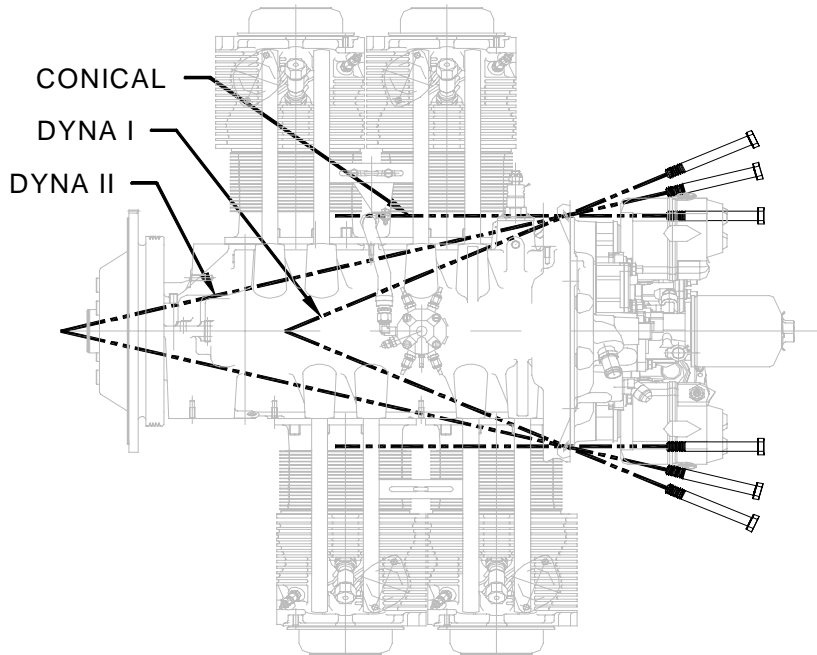

ENGINE MOUNT STYLE

ENGINE STYLE

(PLEASE CIRCLE ONE FOR EACH CATEGORY)

- INDUCTION:** *VERTICAL OR HORIZONTAL*
- CYLINDER TYPE:** *PARALLEL VALVE OR ANGLE VALVE*
- DISPLACEMENT:** *235 OR 290 OR 320 OR 360 OR 540*
- MOUNT STYLE:** *DYNAFOCAL I OR DYNAFOCAL II OR CONICAL*
- FUEL METERING:** *FUEL INJECTED OR CARBURETTED*
- ENGINE SUPPLIER:** *AERO SPORT POWER OR SUPERIOR OR MATTITUCK OR LYCOMING*
- OTHER** _____

CUSTOMER NAME: _____

CUSTOMER NUMBER: _____