

RV-4 STANDARD ORDER FORM

2-13-09

Customer Number (assigned w/ emp kit)		
Name		
Mailing address		
Shipping address (if different)		
Day phone		
e-mail		
Fax		
Eve phone		

PLEASE READ AND SIGN BELOW

1. Kit prices are prices in effect the day order is received.
2. A 25% deposit must accompany kit orders.
3. Customer-instigated delays may result in price increases.
4. Kits must be paid in full before they can be shipped.
5. \$500.00 non-refundable if order is cancelled.
6. Payment in U.S. funds: check, money order, or Visa/Mastercard.
7. Kit/plans orders must be in writing (mail or FAX).
8. Prices are FOB Aurora, Oregon.
9. Freight charges payable on delivery.
10. Van's Aircraft, Inc. cannot assist in certifying kits outside the USA.
11. Prices are subject to change without notice.

Signature:

If you have completed, registered, and flown an RV, put customer number of completed aircraft here: _____

PREVIEW PLANS SET (required purchase before beginning construction)		\$50.00	
RVATOR SUBSCRIPTION Receive 6 printed issues of Van's company newsletter. On-line version available at no charge.	In USA,	\$15.00	
	outside USA	\$20.00	
EMPENNAGE KIT		\$1260.00	
Empennage Options (enter total from reverse side of form)			

WING KIT Prefabricated Spar from Phlogiston Products on order (circle one) YES NO		\$5600.00	
Wing Options (enter total from reverse side of form)			

FUSELAGE KIT		\$3930.00	
Fuselage Options (enter total from reverse side of form)			

FINISHING KIT If you are NOT taking advantage of Van's special OEM pricing on new Lycoming engines, and are obtaining an engine from another source, you must use the Special Finishing Kit order form. Use this form to order a Finishing Kit ONLY if you are purchasing a new engine from Van's.					
				\$5250.00	
Spinner type required (circle one)	Hartzell constant-speed	Sensenich fixed-pitch	Wood fixed-pitch	None (\$120.00 credit)	
Engine type (circle one)	O-320-D1A/D2G	IO-320-D1A	O-360-A1A		

TOTAL CRATING CHARGES (enter total from reverse side of form)		
TOTAL ORDER		
METHOD OF PAYMENT (if credit card, enter number/exp. date)		
AMOUNT ENCLOSED (25% minimum deposit required)		
Authorization to use Credit Card for Final Payment Yes No (circle one)		

VAN'S AIRCRAFT, INC.
 14401 NE Keil Road Aurora, Oregon USA 97002
(503) 678-6545 FAX (503) 678-6560
 ON THE WEB AT: www.vansaircraft.com e-mail: info@vansaircraft.com

OPTIONS

Choices and optional kits that are best installed during construction. Enter the amount for the option you are ordering in the box on the right.
Add the total for each airframe kit and enter that amount on the front of the form.

Circle the crating charges that apply, total, and enter the amount on the front of the form.

WINGTIPS AND RUDDER BOTTOMS ARE DESIGNED FOR LIGHTS. IF YOU ARE <u>NOT</u> INSTALLING LIGHTS CHECK THIS BOX:	
---	--

EMPENNAGE KIT	
<u>ELECTRIC ELEVATOR TRIM:</u> Standard manual elevator trim is controlled with a vernier cable supplied with the Fuselage kit. Electric option uses the same trim tab but a servo motor installed in the elevator replaces the manual push-pull cable. Kit includes servo motor, formed metal parts, hardware and instructions. Weight comparable to standard manual installation. The Electric trim switch can be mounted in any convenient spot.	\$305.00
TOTAL: ENTER ON FRONT OF FORM.	

WING KIT	
<u>PRE-FABRICATED PHLOGISTON SPAR;</u> Fully assembled main wing spar. Gold anodized for corrosion protection. Must be ordered from Phlogiston Products 503-985-3212. Spar will be delivered to Van's and shipped with wing kit.	
<u>CAPACITIVE FUEL SENDING UNITS</u> uses electrically isolated plates at each end of the tank. Light, no moving parts. Works with the EI FL-2C fuel gauge and some engine monitors. Will <u>not work</u> with resistance gauges. Customer must determine suitability. <u>Must</u> be installed during original construction.	\$60.00
<u>FLOAT FUEL SENDING UNITS</u> Arm with float senses fuel level. Works with Van's gauges and many other resistance gauges. Fits standard cover plates in wing kit. Includes gaskets. Two supplied -- one for each wing.	\$54.00
TOTAL: ENTER ON FRONT OF FORM.	

FUSELAGE KIT	
<u>REAR SEAT RUDDER PEDAL KIT</u>	\$135.00
<u>FORWARD BAGGAGE COMPARTMENT</u> Hinged tray under instrument panel.	\$60.00
<u>ELECTRIC FLAPS:</u> Fast acting motor eliminates manual flap handle. More convenient to use.	\$495.00
<u>STATIC AIR KIT:</u> Includes static ports and lines to the instrument panel.	\$19.00
<u>ELECTRIC ELEVATOR TRIM CREDIT:</u> If you ordered electric elevator trim with your empennage, you won't need the manual trim cable. Subtract the cost from the kit price.	Credit. Subtract \$52.00
<u>MANUAL AILERON TRIM:</u> Simple, light and effective spring bias system trims the roll axis. Inexpensive, too.	\$16.00
<u>ELECTRIC AILERON TRIM:</u> Includes servo motor, panel mount rocker switch and all hardware. May also be wired to "china hat" switch sold separately.	\$285.00
TOTAL: ENTER ON FRONT OF FORM.	

CRATING CHARGES (these are NOT shipping charges)				
	Empennage	Wing	Fuselage	Finishing
STANDARD	\$18.00	\$55.00	\$55.00	\$65.00
SEA FREIGHT	\$25.00	\$75.00	\$75.00	\$85.00
TOTAL CRATING CHARGES				

Name: _____ Date: _____ Customer number: _____

VAN'S AIRCRAFT, INC.
14401 NE Keil Road Aurora, Oregon USA 97002
(503) 678-6545 FAX (503) 678-6560

ON THE WEB AT: www.vansaircraft.com e-mail: info@vansaircraft.com

RV-4 SPECIAL FINISHING KIT ORDER FORM

Use when installing engines not supplied by Van's

1-1-09

Customer Number (assigned w/ emp kit)	
Name	
Mailing address	
Shipping address (if different)	
Day phone	
e-mail	
Fax	
Eve phone	

PLEASE READ AND SIGN BELOW

1. Kit prices are prices in effect the day order is received.
2. A 25% deposit must accompany kit orders.
3. Customer-instigated delays may result in price increases.
4. Kits must be paid in full before they can be shipped.
5. \$500.00 non-refundable if order is cancelled.
6. Payment in U.S. funds: check, money order, or Visa/Mastercard.
7. Kit/plans orders must be in writing (mail or FAX).
8. Prices are FOB Aurora, Oregon.
9. Freight charges are collect.
10. Van's Aircraft, Inc. cannot assist in certifying kits outside the USA.
11. Prices are subject to change without notice.

Signature: _____

If you have completed, registered, and flown an RV, put customer number of completed aircraft here: _____

FINISHING KIT		\$5250.00	
Crating Charge (enter one)		Regular \$65.00, Sea Freight \$85.00	
DEFINING YOUR ENGINE			
<p>If you are using a new Lycoming from Van's use the regular Finish Kit Order Form. If you are using an engine from some other source, use this form. Van's engine mounts and cowls fit the engines we sell. NOTE THAT COWLS FOR HORIZONTAL INDUCTION ENGINES ARE NOT AVAILABLE FOR RV-4. Other engine suppliers produce a wide variety of engines that may or may not correspond to Lycoming models. To provide us the information we need, you must complete the ENGINE IDENTIFICATION form on the reverse by circling the items that describe your engine. Without this information we cannot accept your order.</p> <p>If you are installing an engine that is not compatible with Lycoming style mounts or cowl, you may delete these items for credit. The exact amount of the credit will be determined by Van's.</p> <p>It is the customer's responsibility to provide accurate information. Van's Aircraft, Inc. is not responsible for costs incurred replacing or returning incorrectly ordered parts.</p>			
ENGINE MOUNT	Use data sheet on opposite side	None	
COWL TYPE	Use data sheet on opposite side	None	
SPINNER TYPE NOTE: if supplying own spinner or buying new MT prop (supplied with spinner) -circle none.	Hartzell constant-speed	Sensenich fixed-pitch	Wood fixed-pitch
			None (\$120.00 credit)

TOTAL ORDER	
METHOD OF PAYMENT (if credit card, enter number/exp. date)	
AMOUNT ENCLOSED (25% minimum deposit required)	
Authorization to use Credit Card for Final Payment Yes No (circle one)	

VAN'S AIRCRAFT, INC.

14401 NE Keil Road Aurora, Oregon USA 97002

(503) 678-6545 FAX (503) 678-6560

ON THE WEB AT: www.vansaircraft.com e-mail: info@vansaircraft.com

ENGINE IDENTIFICATION

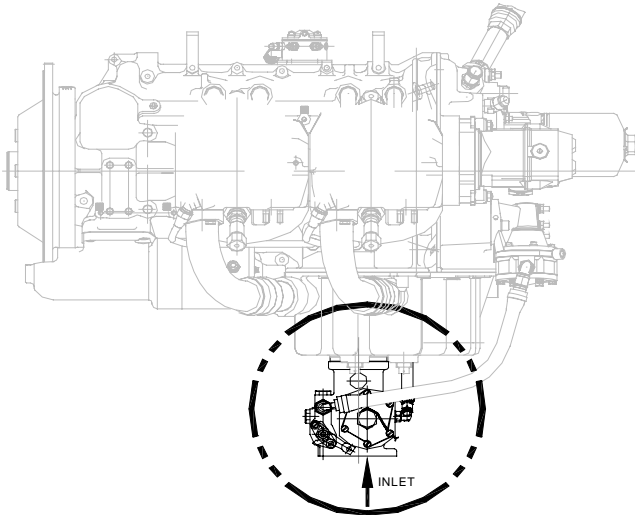

VERTICAL INDUCTION

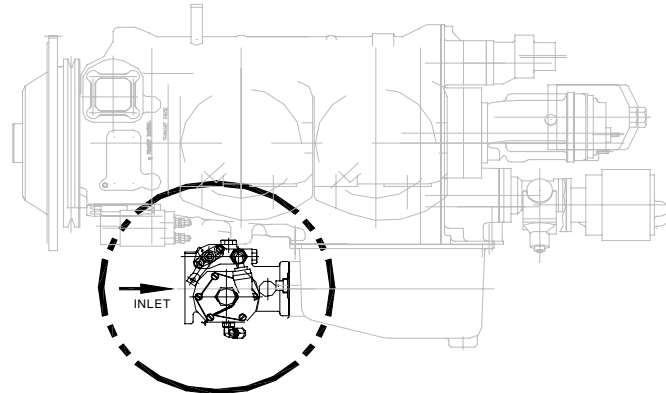

HORIZONTAL INDUCTION

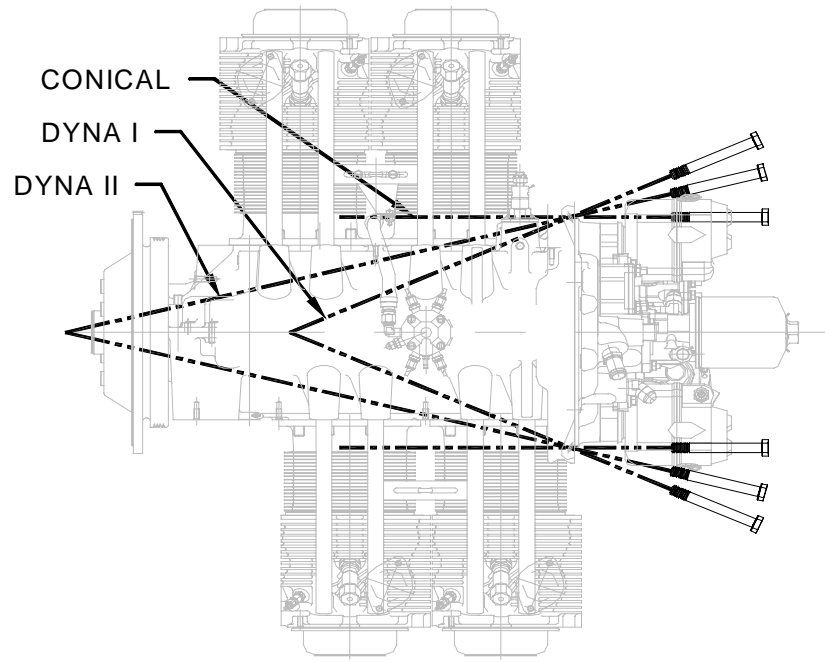

ENGINE MOUNT STYLE

VALVE COVER SHAPE



ANGLE VALVE
 EXAMPLE:
 IO-360 A1B6 (200 HP)

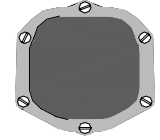

PARALLEL VALVE
 EXAMPLE:
 I(O)-320 D1A (150 - 160 HP)
 I(O)-360 A1A (180 HP)

ENGINE STYLE

(PLEASE CIRCLE ONE FOR EACH CATEGORY)

- INDUCTION:** VERTICAL OR HORIZONTAL
- CYLINDER TYPE:** PARALLEL VALVE OR ANGLE VALVE
- DISPLACEMENT:** 235 OR 290 OR 320 OR 360 OR 540
- MOUNT STYLE:** DYNAFOCAL I OR DYNAFOCAL II OR CONICAL
- FUEL METERING:** FUEL INJECTED OR CARBURETTED
- ENGINE SUPPLIER:** AERO SPORT POWER OR SUPERIOR OR MATTITUCK OR LYCOMING
- OTHER:** _____

CUSTOMER NAME: _____

CUSTOMER NUMBER: _____