

September 4, 2003

GASCOLATOR RECALL

This Gascolator Recall notice replaces the Gascolator Required Inspection published in February, 2001 *RVator*. This notice also replaces the GAS-3 Gascolator letter dated June 8, 2001.

ACTION

If you have an "OLD STYLE" GAS-3 gascolator please:

Notify U.E.I. at 503 992-0015

****OR****

Ship to: U.E.I.

9865 NW 307th Ave.

P.O.Box 511

North Plains, OR 97133

U.E.I. will replace this bowl at no charge. **DO NOT RETURN GASCOLATOR BOWLS TO VAN'S AIRCRAFT.**

APPLICABILITY

The "OLD STYLE" GAS-3 gascolator bowls differ from "new style" gascolator bowls in the number of flats at the bottom of the bowl. "OLD STYLE" BOWL END CAPS HAVE TEN FLATS. "New style" bowl end caps have twelve flats. Only gascolators with "OLD STYLE" bowl end caps need to be replaced.

If the GAS-3 gascolator has not been installed, then the complete gascolator assembly should be returned to U.E.I.

If the GAS-3 gascolator is installed on a flying or nearly ready to fly aircraft then only the gascolator bowl should be returned to U.E.I. This is to minimize disruption to those pilot/owners with affected gascolator bowls.

GASCOLATOR BOWL END VIEW

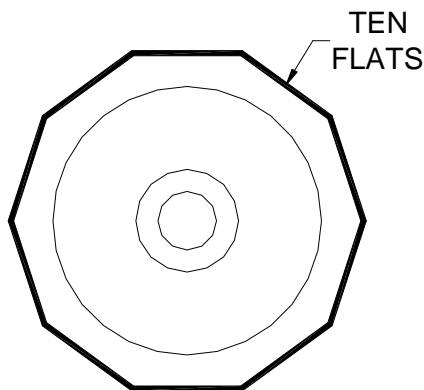

OLD STYLE

RETURN TO U.E.I.

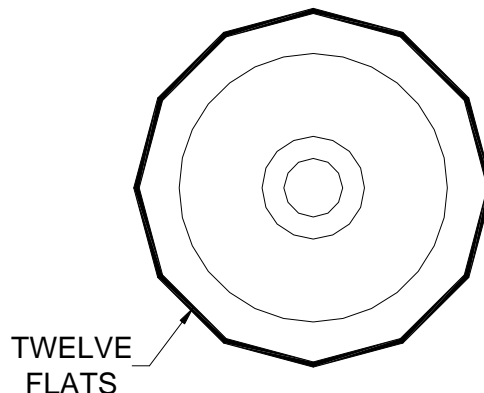

NEW STYLE

NOT AFFECTED BY RECALL