

## RV-12 UPDATE

November 6, 2008

So, where do we stand on RV-12 as we head into a Northern Hemisphere winter?

One hundred sixty builders have ordered wing kits and started RV-12s. Judging by the very low volume of RV-12 related calls at the Tech Help desk, they are going together quickly and easily.

We are currently shipping Wing and Fuselage kits, and will start taking orders for Empennage kits at high noon on November 12.

For the curious, empennage kits will come in two containers; one cardboard box 18x15x14" weighing 4 lbs and one wood crate 114x39x10" that weighs just under 200 lbs. This may change slightly as we go, but it's good enough for planning purposes.

Finish kits, which will contain the canopy (the rear window ships with the Fuselage kit – completely trimmed and pre-punched!), the engine mount, wheels/brakes, nose gear components, wiring harness and fuel tank components, are in the final stages of development.

We are often asked about the price and delivery time on Rotax engines. Recent economic events, especially rapidly fluctuating currency exchange rates, make it impossible to make any meaningful predictions. About all we can say is we plan to have engines in time for the best price possible.

We've talked a lot about the quality of the plans and instructions included in RV-12 kits. Below are of some representative pages.

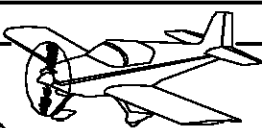

**Step 1:** Cleco one of the W-1212 Hinge Assemblies to each of the W-1207B Rear Spar Doubler Plates. Orient the parts as shown in Figure 1.

**Step 2:** Rivet only the inboard flange of the W-1212 Hinge Assemblies to each of the W-1207B Rear Spar Doubler Plates using rivets indicated in Figure 2. Identify the hinge assembly and rear spar doubler plate as the Left and Right Doubler Assembly per call outs in Figure 1.

**Step 3:** Cleco the Left and Right Doubler Assembly to the inboard end of the W-1207A-L & -R Rear Spar Web as shown in Figure 1.

**Step 4:** Cleco the W-1207C-L & -R Tip Attach Angles to the outboard end of the W-1207A-L & -R Rear Spar Web. Cleco the as shown in Figure 1.

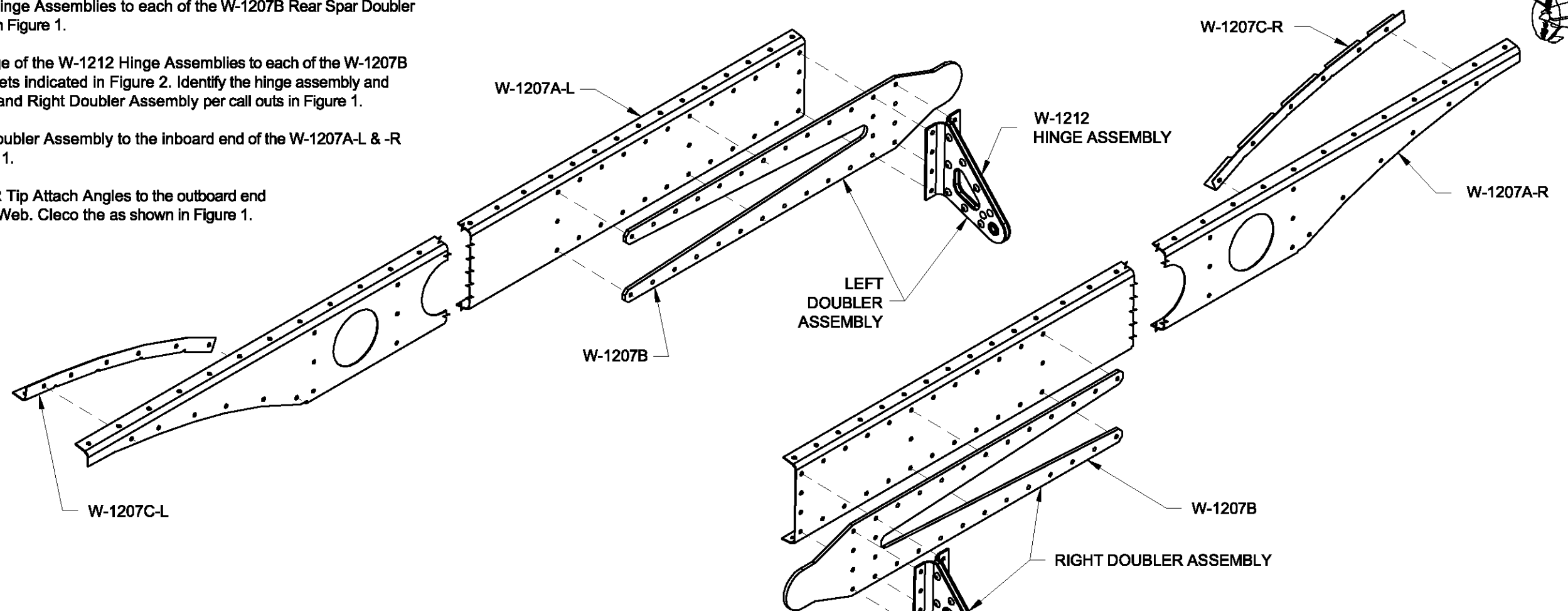
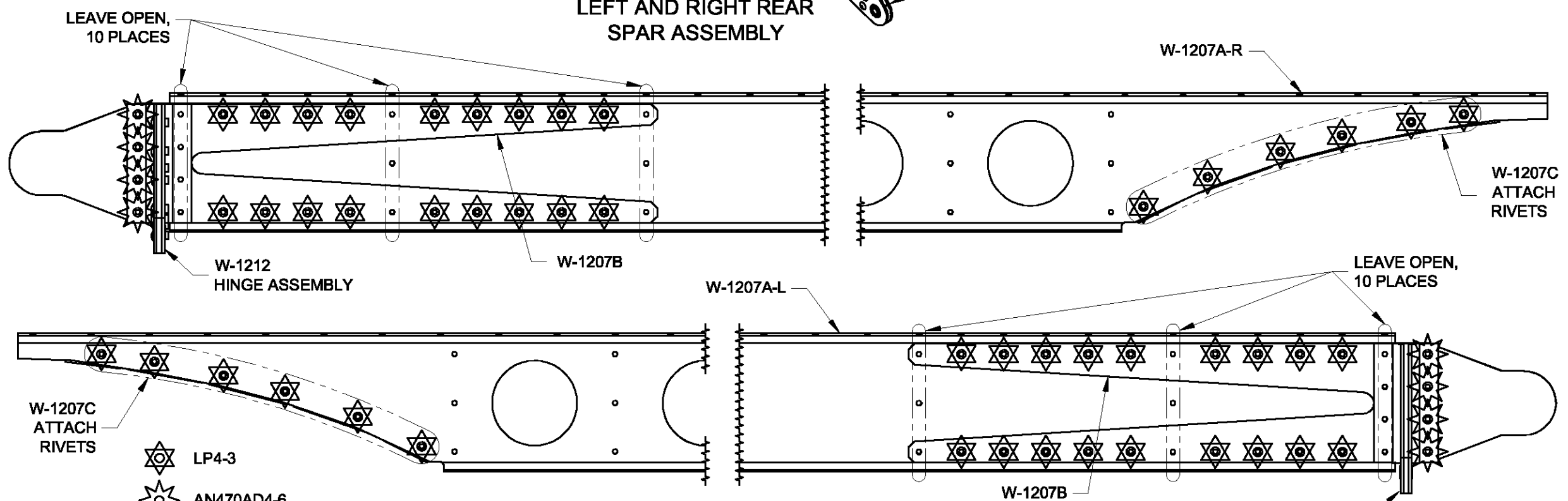

**FIGURE 1:**  
LEFT AND RIGHT REAR SPAR ASSEMBLY

**Step 5:** Rivet the Left and Right Doubler Assemblies to the W-1207A-L & -R Rear Spar Webs using rivets indicated in Figure 2. Leave open the called out holes that will later correspond to the wing ribs.

**Step 6:** Rivet the W-1207C-L & -R Tip Attach Angle to the W-1207A-L & -R Rear Spar Web using rivets called out in Figure 2.

Hereafter refer to these subassemblies as the Left and Right Rear Spar Assembly.



**FIGURE 2:**  
LEFT AND RIGHT REAR SPAR ASSEMBLY RIVETS

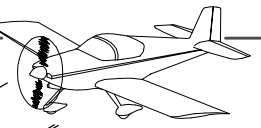

Step 1: Separate the two sets of F-1203E Bulkhead Doublers by removing the hatched areas shown in Figure 1.

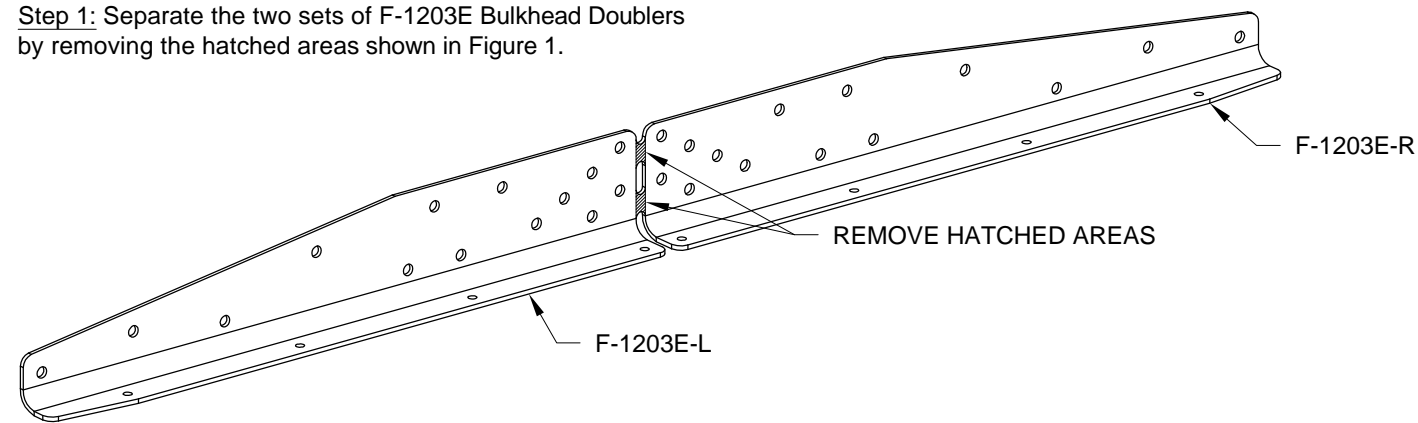

**FIGURE 1: F-1203E BULKHEAD DOUBLER**

**NOTE:** Where possible, install rivets in the F-1203A Bulkhead with the manufactured heads on the forward side.

Step 2: Rivet the F-1203E-L & -R Bulkhead Doublers to both ends of the F-1203A Bulkhead, to the F-1203C Stub Spar Receptacles, and F-1203D-L & -R Stub Spar Receptacle Supports using the rivets called out in Figure 2. As indicated in the figure, do not install rivets in the four holes in both sets of bulkhead doublers, or the eight holes in the spar receptacle supports outbd of the doublers.

Step 3: Rivet the flanges of the F-1203E-L & -R Bulkhead Doublers to each other using the rivets called out in Figure 2. It is acceptable to squeeze these rivets with two flush rivet sets.

Step 4: Rivet the Control Column Mount Assemblies (and their associated one-leg nutplates) to the F-1203A Bulkhead using the rivets indicated in Figure 2. Do not rivet the two bottom holes in both assemblies.

Step 5: Rivet the four nutplates to sloped flanges of both Control Column Mount Assemblies using the rivets called out in Figure 2.

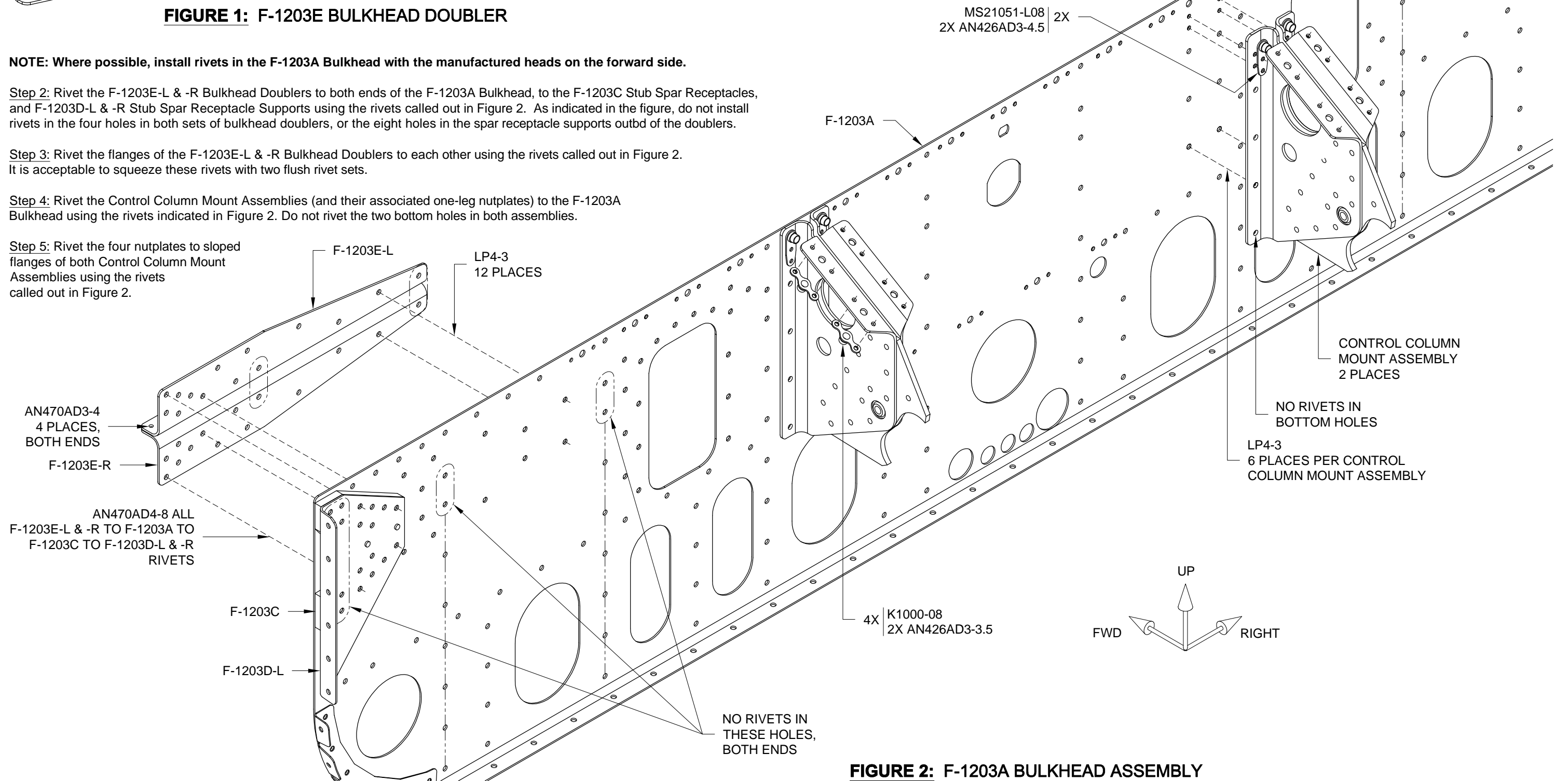

**FIGURE 2: F-1203A BULKHEAD ASSEMBLY**